

Wciągnik elektryczny linowy THETA 8000

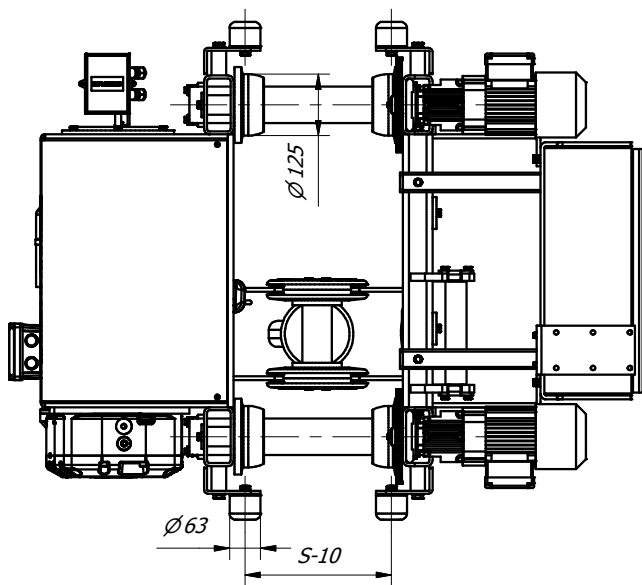
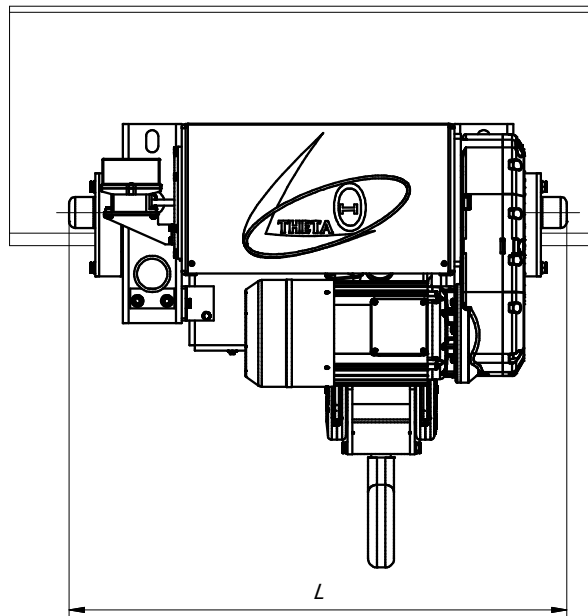
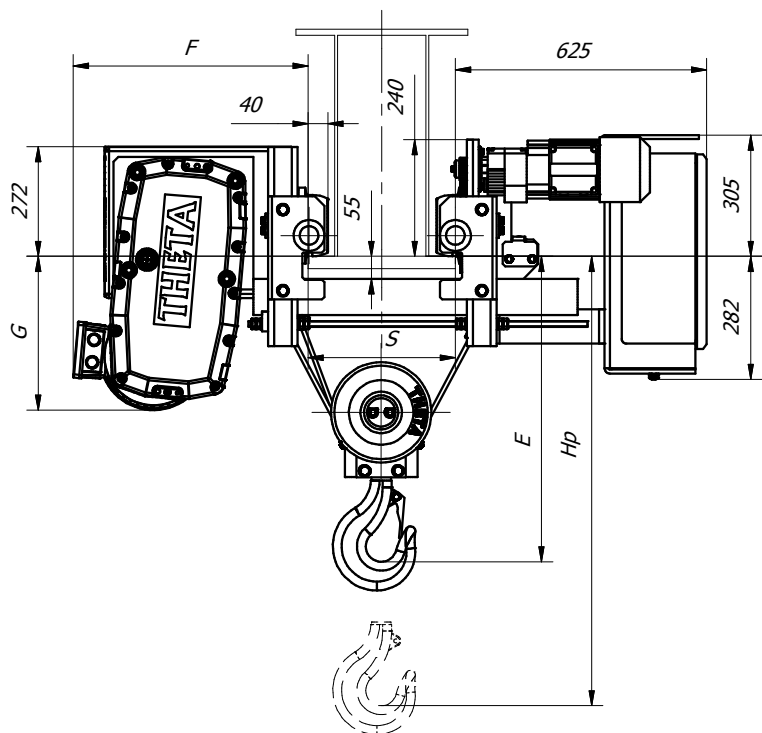

	vp [m/min]	vj [m/min]	P [kW]	F [mm]	G [mm]	G.N.P.	+m [kg]
A	4/0,7	20/5	7,6/1,2	573	375	3m	-
B	5/0,8	20/5	9,5/1,5	573	375	3m	5
C	6,3/1	20/5	9,5/1,5	573	375	2m	5
D	8/1,3	20/5	12,5/2	573	375	1Am	15

	TH8006A,B,C,D	TH8006A,B,C,D
Hp [m]	6	9
L [mm]	1078	1273
m [kg]	680	704

S [mm]	100-200	250	300	350	400	450	500	550	600
E min. [mm]	700	680	680	680	700	770	810	860	910